

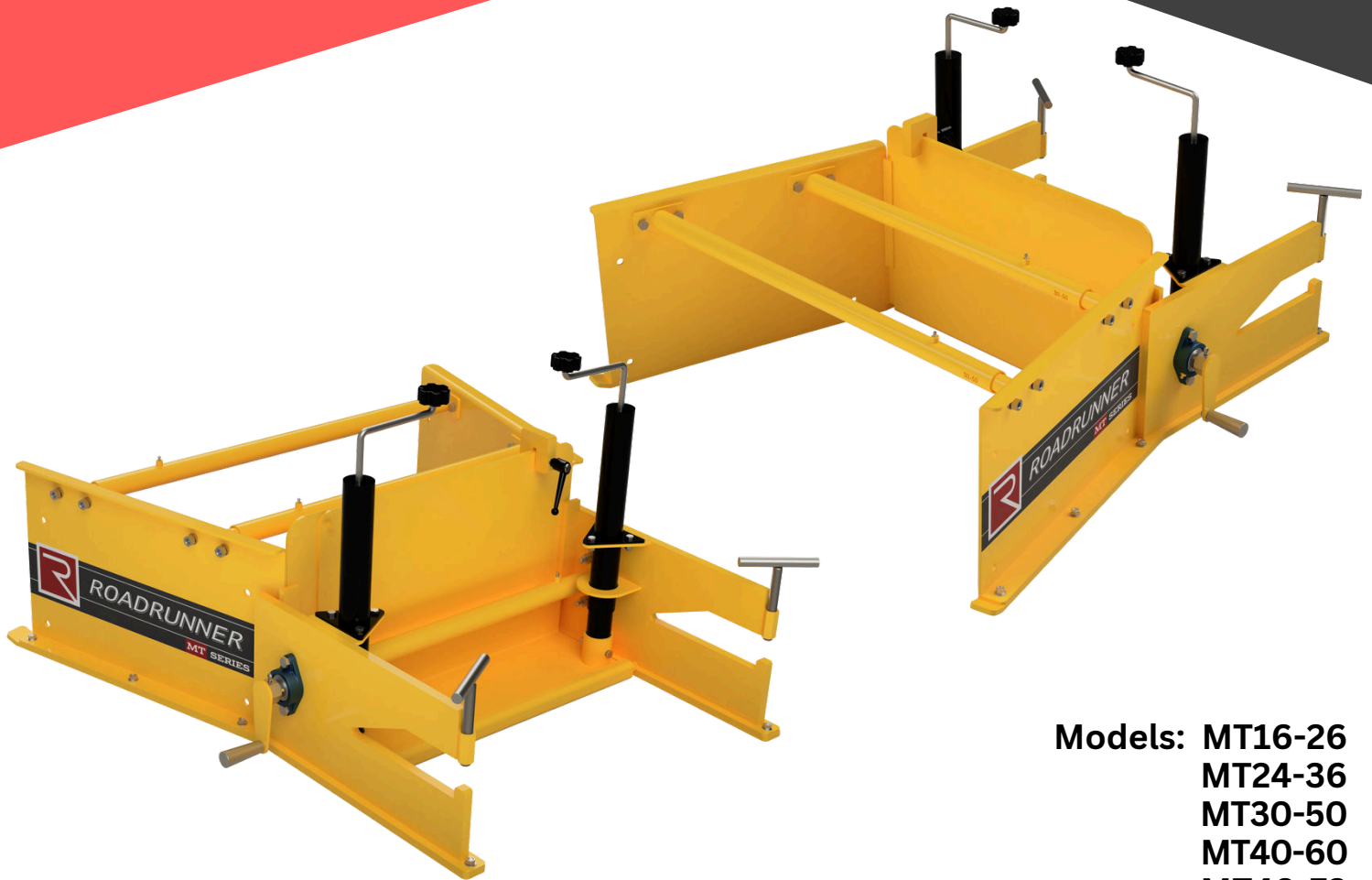

ROADRUNNER
EQUIPMENT LLC.



Models: MT16-26
MT24-36
MT30-50
MT40-60
MT48-72

OWNER'S MANUAL

MULTI-TASK

TRENCH PAVER



Read, Understand, and Follow this manual, which provides information and procedures to operate and maintain your Roadrunner Equipment paver safely.

Contents

1. INTRODUCTION	4	6. Maintenance	17
1.1 Intended Usage	4	6.1 Maintenance Safety	17
1.2 Operator Orientation	4	6.2 Practice Safe Service Procedures	17
1.3 Specifications	4	6.3 Bolt Torque Requirements	18
1.4 Serial Number Location	4	6.4 Welding Repairs	18
1.5 Owner / Operator Manual Storage	4	6.5 Service Record	19
1.6 Product Improvements	5		
1.7 Disposal of Eqpt at End of Useful Life	5		
1.8 Unanswered Questions	5		
2. Safety	6	7. Parts Section	20
2.1 General	6	7.1 Ordering Parts	20
2.2 Safety Alert Symbols	6	7.2 Contact Information	20
2.3 Safety Icons	7	7.3 Bill of Materials / Parts	21
2.3.1 Personal Protection / Important Information	7	7.4 Screeds	22
2.3.2 Prohibited Actions	7	7.5 Side Panel	23
2.3.3 Hazard Avoidance	7	7.6 Width Adjustment	24
2.4 General Safety	8	7.7 Teletubes	25
2.5 Hydraulic Safety	8	7.8 Decals	26
2.6 Safety Signs	9		
2.7 Operation Safety	9	8. Warranty	27
2.8 Transportation Safety	9		
2.9 Storage Safety	9		
2.10 Maintenance Safety	9		
2.11 Training	9		
3. Operation	10		
3.1 User Safety	10		
3.2 Machine Requirements	10		
3.2.1 Machine Specifications	11		
3.2.2 Tractor Specifications	11		
3.3 Initial Setup and Attachment	11		
3.4 Pre-Operation Checklist	12		
3.5 Operation	12		
3.5.1 Adjustment	12		
3.5.2 Paving	13		
3.5.3 Example of Use	13		
3.6 Detaching From Machine	14		
4. Transporting	15		
4.1 Highway and Transport Safety	15		
4.2 Pre-Transport Checklist	15		
5. Storage	16		
5.1 Placing in Storage	16		
5.2 Removing from Storage	16		

1. Introduction

The Multi-Task Trench Paver is an attachment that mounts to a skid steer loader bucket or small utility tractor bucket. It is designed to pave, or backfill, trenches and other small paving projects.

Note: The specific term “Multi-Task Trench Paver” will be referred to simply as “paver” throughout the rest of this manual. The term skid steer loader or small utility tractor will be referred to as “machine” throughout this manual.

Read, understand, and follow the manual carefully to become familiar with your new paver. Ultimately, it is our desire that you will be operating your paver as a seasoned professional in very little time!

1.1 Intended Usage

Do not use this paver for any other purpose than its intended use of paving and backfilling trenches or road widening.

Do not use an oversized machine; the paver is intended to be used on machines rated up to 110 HP or a 3000 pound lift capacity.

1.2 Operator Orientation

The directions, left, right, front, and rear, as mentioned throughout this manual, are as seen from operator’s seat, facing in the direction of travel.

1.3 Specifications

	<u>Length</u>	<u>Width</u>	<u>Height</u>	<u>Weight (lbs)</u>
MT16-26	48"	42"	30"	360
MT24-34	48"	42"	30"	380
MT30-50	48"	50"	30"	400
MT40-60	48"	60"	30"	420
MT48-72	48"	66"	30"	460

Specifications subject to change without notice.

1.4 Serial Number Location

The paver’s serial number plate (1) is located on the outside of the arch tube weldment. Please use these numbers when requesting service, seeking information, or ordering parts.

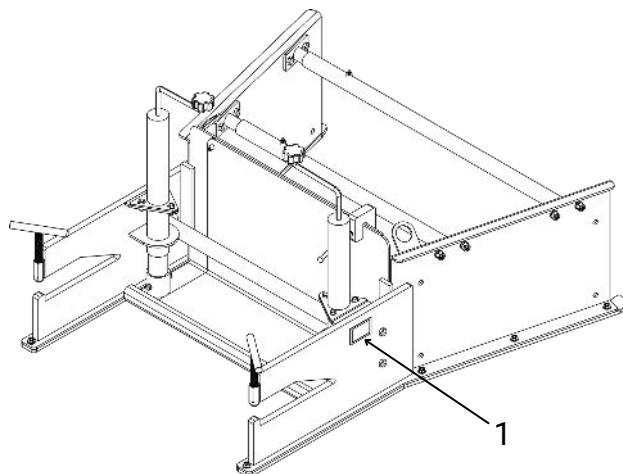

Record the serial and model numbers in the space provided for easy reference when contacting Roadrunner Eqpt. LLC with questions.

Serial Number: _____

Date of Purchase: _____

It is recommended to email your purchase information to: **contact@roadrunnerblade.com**
Please include: name, address, phone #, serial #, purchase date, and dealer where you purchased your paver.

1.5 Owner/ Operator Manual Storage

Store this Owner/ Operator Manual and other operating materials in a safe location for future reference.

1.6 Product Improvements

Because Roadrunner Eqpt. LLC maintains an ongoing program of product improvement, we reserve the right to make improvements in design, or changes in specifications, without incurring any obligation to install them on pavers previously sold.

1.7 Disposal of Equipment at End of Useful Life

Roadrunner Eqpt. LLC pavers are designed for the specific purpose of paving and backfilling trenches. When this paver is no longer capable of performing its intended use, it should be dismantled and scrapped. Do not use any materials or components from this paver for any other purpose.

1.8 Unanswered Questions

If you have any questions not answered in this manual, require additional copies, or the manual is damaged, please contact your dealer or:

Roadrunner Equipment LLC
155 Jalyn Drive
New Holland, PA 17557

Phone: (717) 405-7785
Email: contact@roadrunnerblade.com

This manual is also available for download at:
www.roadrunnerblade.com

2. Safety

2.1 General

Most work-related accidents are caused by failure to observe basic safety rules or precautions. An accident can often be avoided by recognizing potentially hazardous situations before an accident occurs. As you operate and maintain the paver you must be alert to potential hazards.

Improper operation and/or maintenance of this paver could cause a dangerous situation that results in property damage, personal injury, or death.

WARNING



Do not use the paver until you read, understand, and follow the information contained in this manual and all related equipment manuals. Do not use the paver for anything other than its intended purpose.



Safety precautions and warnings are provided in this manual and on the paver. If these precautions and warnings are not followed, bodily injury or death could occur to you or to other persons.

Roadrunner Eqpt LLC cannot anticipate every possible circumstance that might involve a potential hazard. The warnings in this manual and on the product are, therefore, not all-inclusive. If a method of operation not specifically recommended by us is used, you must satisfy yourself that it is safe for you and for others. You should also ensure that the paver will not be damaged or be made unsafe by the operating or maintenance methods that you choose.

The information, specifications, and illustrations in this manual are based on the information that was available at the time this material was written and can change at any time.

2.2 Safety Alert Symbol



This is the safety alert symbol. It is used to alert you to potential personal injury hazards. The symbol is followed by a signal word such as “WARNING” or “CAUTION” depending on the severity of the potential hazard. Obey all safety messages that follow this symbol to avoid possible injury or death. This manual contains WARNINGS, CAUTIONS, NOTICES, SAFETY INSTRUCTIONS, and NOTES. Warnings, Cautions, and Safety Instructions must be followed to prevent the possibility of personal injury or death due to improper operation. Notices and Notes help prevent paver or property damage.

WARNING

Indicates a potentially hazardous situation which, if not avoided, **COULD** result in death or serious injury.

CAUTION

Indicates a potentially hazardous situation which, if not avoided, **MAY** result in minor or moderate injury.

NOTICE

Indicates that paver or property damage can result if instructions are not followed.

SAFETY INSTRUCTIONS

Indicates specific safety related instructions or procedures.

NOTE: Contains additional information important to operation or a procedure.



2.3 Safety Icons

This manual and the paver has numerous safety icons. These safety icons provide important operating instructions which alert you to potential personal injury hazards.

2.3.1 Personal Protection / Important Information

-   *Read the manual*
-  *Maintenance procedure*
-  *Eye protection*
-  *Hearing protection*
-  *Hand protection*
-  *Foot protection*
-  *First aid kit*
-  *Use proper tools*
-  *Use OEM parts*
-  *Use ROPS and seat belt*
-  *Maintain safety signs*
-  *Place in park*
-  *Remove key*
-  *Stop engine*
-  *Visibility - slow moving vehicle (SMV)*
-  *Set parking brake*

2.3.2 Prohibited Actions

-  *Do not alter or modify*
-  *Do not leave out tools*

-  *Do not weld*
-  *No riders*
-  *No children*
-  *No alcohol*
-  *No drugs*

2.3.3 Hazard Avoidance

-  *Crushing hazard*
-  *Crushing hazard*
-  *Slipping hazard*
-  *Tripping hazard*
-  *Falling hazard*
-  *Hose damage hazard*
-  *Explosive separation hazard*
-  *Safety alert symbol*
-  *Release all pressure (zero pressure)*
-  *Trapped air pressure hazard*
-  *Trapped pressure hazard*
-   *High-pressure fluid hazard*
-  *Defective or broken part*
-  *Falling hazard*
-  *Maintain safe distance*
-   *Pinch point hazard*
-  *Crush hazard*
-  *Rollover hazard*

2.4 General Safety

WARNING



Read, Understand, and Follow Manual

To prevent personal injury or even death, be sure you read, understand, and follow all of the instructions in this manual and other related OEM equipment manuals! This paver was designed for a specific application; DO NOT modify or use this paver for any application other than that for which it was designed. Pavers operated improperly or by untrained personnel can be dangerous! Inexperienced operators should receive instruction from someone familiar with the paver and the machine before being allowed to operate the paver.



Do Not Operate

Do not use the paver if it is in need of repair. If you believe the paver has a defect which could cause injury or death, you should immediately stop using the paver.



Fall Hazard

Do not use the paver as a platform. Do not stand on top of the paver at any time. Do not ride on the paver or allow others to ride on it.



Pinch Point Hazard

Keep hands and feet away from any moving parts to prevent them from getting pinched.



Falling Hazard

Do not allow riders on the machine or paver at any time. Falling can result in severe injury or death.



Impaired User Hazard

Do not attempt to operate or maintain the paver under the influence of drugs or alcohol. Consult your doctor before using the paver while taking prescription medications.

WARNING



Stay Clear

Clear the area of people, especially small children, before using the paver. Under no circumstances should young children be allowed to work with or around the paver.



Not A Lifting Device

Do not use the paver to lift other objects.

2.5 Hydraulic Safety



High-Pressure Fluid Hazard

Hydraulic fluid escaping under pressure can penetrate the skin. Openings in the skin and minor cuts are susceptible to infection from hydraulic fluid. If injured by a concentrated high-pressure stream of hydraulic fluid, seek medical attention immediately. Without immediate medical treatment, serious infection or toxic reaction can develop if hydraulic fluid penetrates the surface of the skin.



Visual Inspection

Before applying pressure to the system, make sure all components are tight and that the hydraulic lines, hoses, and couplings are not damaged. Replace any worn, cut, abraded, flattened, or crimped hoses.



Personal Protective Equipment (PPE)

Wear proper hand and eye protection when searching for a high-pressure hydraulic leak. Use a piece of wood or cardboard as a backstop instead of hands to identify and isolate a leak.



Trapped Air Hazard

When installing, replacing, or repairing hydraulic system cylinders or parts, make sure that the entire system is charged and free of air before resuming operations. Failure to bleed the system of all air can result in improper machine operation, causing severe injury.

WARNING



Explosion Separation Hazard

Do not make any temporary repairs to the hydraulic lines, fittings, or hoses using tape, clamps, or adhesives. The hydraulic system operates under extremely high pressure and temporary repairs may fail suddenly and create a hazardous/dangerous situation.

NOTICE

Make sure components in the hydraulic system are kept clean and in good working condition. The most common reason for hydraulic component failure is contamination of the oil.

Keep all hydraulic fittings completely clean.

Repair any fittings, hoses, or other components where leakage is observed.

Clean up any spilled hydraulic oil.

2.6 Safety Signs

Refer to section “2. Safety” on page 6 for safety recommendations related to using the paver.

2.7 Operation Safety

Refer to section “3.1 User Safety” on page 10 for safety recommendations related to using the paver. All applicable safety recommendations in other sections should also be followed.

2.8 Transporting Safety

Refer to “4.1 User Safety” on page 15 for safety recommendations related to transporting the paver. All applicable safety recommendations in other sections should also be followed.

2.9 Storage Safety

Refer to “5.1 Placing in Storage” on page 16 for safety recommendations related to storing the paver. All applicable safety recommendations in other sections should also be followed.

2.10 Maintenance Safety

Refer to section “6. Maintenance Safety” on page 17 for safety recommendations related to maintaining the paver. All applicable safety recommendations in other sections should also be followed.

2.11 Training

Anyone who will be using and/or maintaining the paver must read and clearly understand ALL safety, operation, and maintenance information presented in this manual, other related OEM manuals, and the safety signs. If you do not understand any information in this manual, see your dealer or contact Roadrunner Eqpt LLC before proceeding. Do not use or allow anyone else to use this paver until all information has been reviewed. Annually review this manual before the season start-up. Make periodic reviews of SAFETY and OPERATION a standard practice. An untrained operator is not qualified to use this paver.

3. Operation

3.1 User Safety

Refer to “2.4 General Safety” on page 8 for additional safety information.

WARNING

Roll Away Hazard



Before leaving the operator’s seat, make sure the engine is stopped, the transmission is placed in park, the key is removed, and the parking brake is set.



Crush Hazard

The weight of the machine, plus the paver, if it rolls onto a person, could cause serious crushing injury or death.



If using a small compact or utility tractor, it must be equipped with a Roll Over Protective Structure (ROPS) and a seat belt. A crushing hazard could occur if the operator is ejected from the seat while the tractor is in motion. Fasten the seat belt whenever the tractor is moving.



Entanglement Hazard

If using a small compact or utility tractor, keep hands and clothing clear of any rotating parts. Stay clear of the paver while it is moving.

SAFETY INSTRUCTIONS

The following safety instructions are provided to help prevent injury or limit damage to the paver.

- It is the owner’s responsibility to make sure any person using the paver, especially if it is loaned or rented, has been thoroughly trained on its proper and safe use.
- Be certain only physically-able persons will use the paver.

SAFETY INSTRUCTIONS

- Users who have not read and understood all operating and safety instructions are not qualified to use the paver.
- If the elderly are assisting with the work, their physical limitations need to be recognized and accommodated.
- Never allow children to operate the paver.
- Be especially observant of the operating area and terrain – watch for loose fill, holes, rocks or other hidden hazards. Always inspect the area prior to operation
- Be careful at the edge of ditches or gullies. Be careful when working on inclines.
- Do not use excessive speed when paving.
- Allow for paver length when making turns.

3.2 Machine Requirements

WARNING



Machine Operator Manual

Always refer to the machine’s manual to ensure compatibility and maximum safety.

SAFETY INSTRUCTIONS

- Do not use an oversized machine.
- Operating the paver with a machine that does not meet the specified requirements may cause machine or paver damage and be a potential danger to the operator or bystanders.
- Always review the “controls” section of the machine’s Operator Manual to be familiar with the location, settings, and function of the controls. Be familiar with all controls before using this paver.

3.2.1 Machine Specifications

The machine must be equipped with a Roll Over Protective Structure (ROPS) (cab or roll bar) and seat belt to protect the operator.

3.2.2 Tractor Specifications

WARNING



Rollover Hazard

To avoid serious injury or death from falling, runover, rollover, or crushing, the tractor must have an approved Roll-Over Protective Structure (ROPS) or ROPS cab and seat belt.

The tractor must be equipped with an approved Roll-Over Protective Structure (ROPS) or ROPS cab and seat belt.

- Keep ROPS locked in the UP position.
- Only operate the tractor when seated in the tractor seat.
- Always fasten seat belt whenever the tractor is moving.
- Use caution when transporting over uneven terrain and slow down for turns.

If working around dry grass or vegetation, to reduce the risk of fire, do not use a tractor with an under-frame exhaust.

Whenever traveling on a public roadway, the tractor must be equipped with proper warning lighting and a Slow Moving Vehicle (SMV) emblem which are clearly visible from the rear of the tractor.

Maintain all manufacturer's safety shields and guards.

- Always replace shields and guards that were removed for access to connect the paver.
- Never operate the tractor PTO with the PTO master shield missing or in the raised position.

3.3 Initial Setup and Attachment

CAUTION



Pinch Point Hazard

Use caution when connecting the paver to the machine. Keep hands and feet from under the paver and clear of pinch points. Do not allow anyone to stand between the machine and paver during attachment.

- Attach skid steer bucket, or tractor bucket, to machine.
- Attach paver to desired location on bucket (fig.3.1-3.4).
- Tighten the paver's "T"-handles securely.

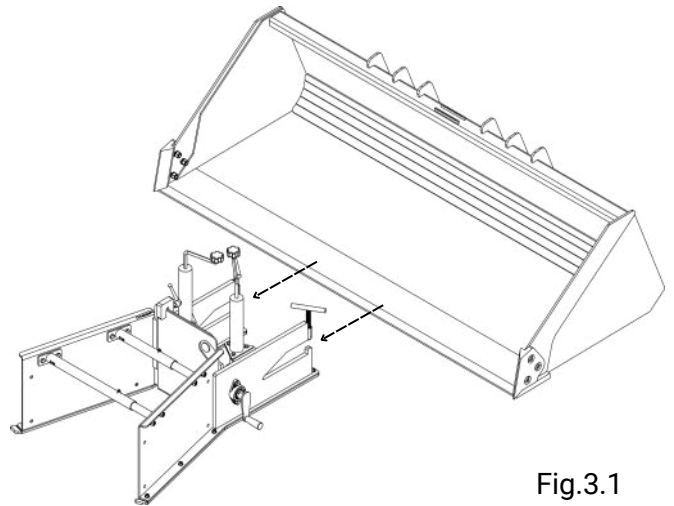

Fig.3.1

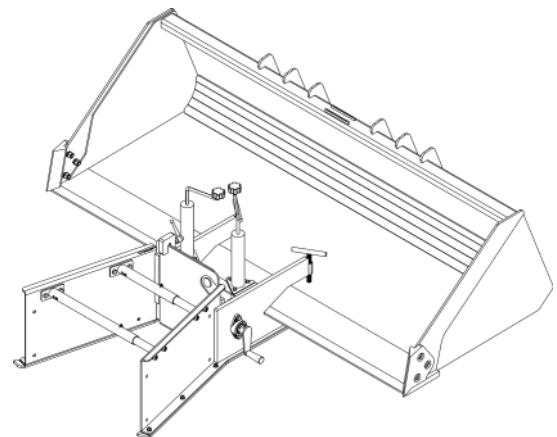

Fig.3.2

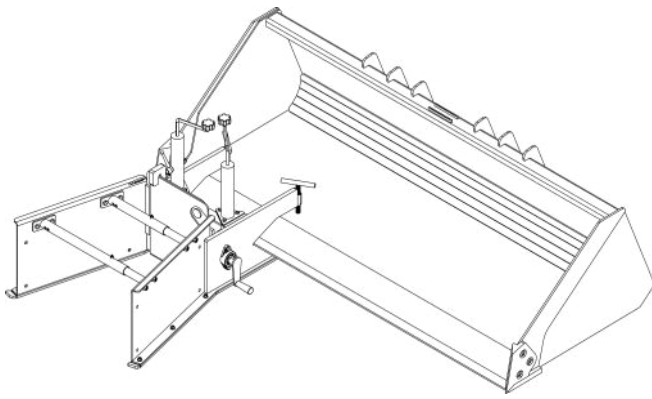

Fig.3.3

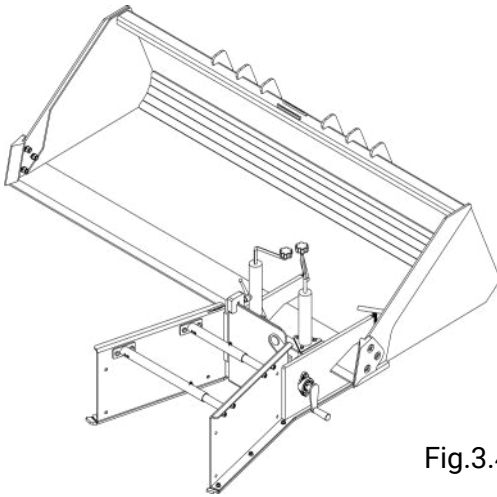

Fig.3.4

CAUTION



Stay Clear
Stay clear of the paver when it is raised and lowered.

3.4 Pre-Operation Checklist

Before each use of the paver, the following areas should be checked:

Checklist Before Each Use	
✓	Task
	Make sure the paver is positively attached to the machine. Refer to “3.3 Initial Setup and Attachment” on page 11.
	If the machine uses tires, make sure they are inflated properly and the lug nuts are tight.
	Visually inspect the paver for any loose bolts, worn parts, or cracked welds. Make necessary repairs before using paver.
	Make sure all retainer clips and pins are in place.
	Make sure the operating area is clear, especially of children and animals.

3.5 Operation

The paver is designed for paving, trench filling, and road widening.

3.5.1 Adjustment

Depth Adjustment

The paver is equipped with two adjustable jacks allowing for paving depth adjustment (fig.3.5 #1). The paver can be adjusted to a depth of 5 inches below grade and up to 3 inches above grade.

Width Adjustment

The paver is also designed to be able to open and close, using the manual adjustment handle located on the side of the paver (fig.3.5 #2).

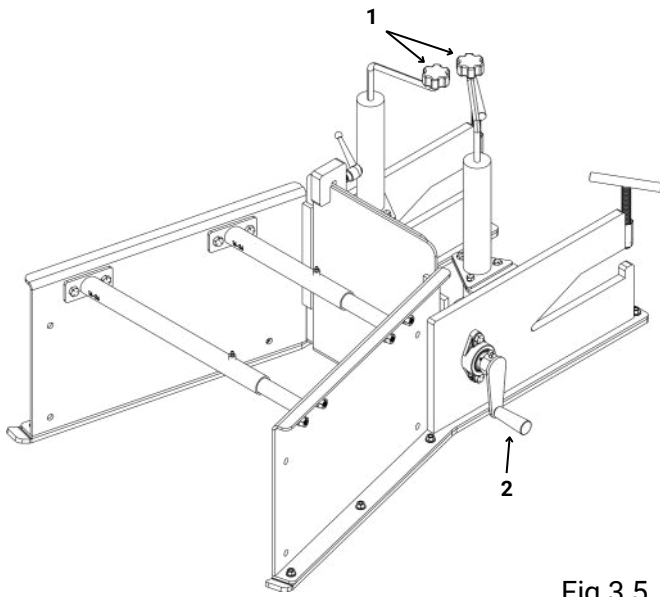
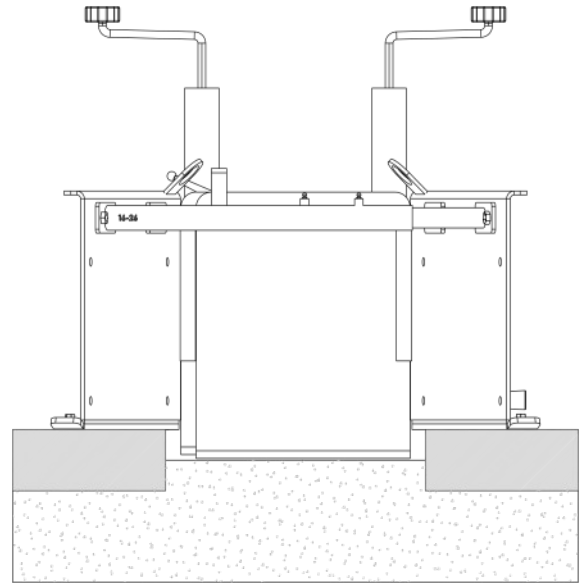

Fig.3.5

3.5.2 Paving

1. Make sure the paver skid plates are level to the ground.
2. Set left and right-hand sides of the screeds to the same height at the desired depth.
3. Adjust the paver to desired width. It may be necessary to raise the paver slightly off the ground to make the adjustments.
4. Once paving is complete, the roadway material should be packed into place. Packing is important to prevent the surface material from quickly being moved, resulting in ripples, waves, or tire channels.

3.5.3 Example of Use



Screeds can be adjusted in depth, down to 5" below grade, to use in spreading the base layer.

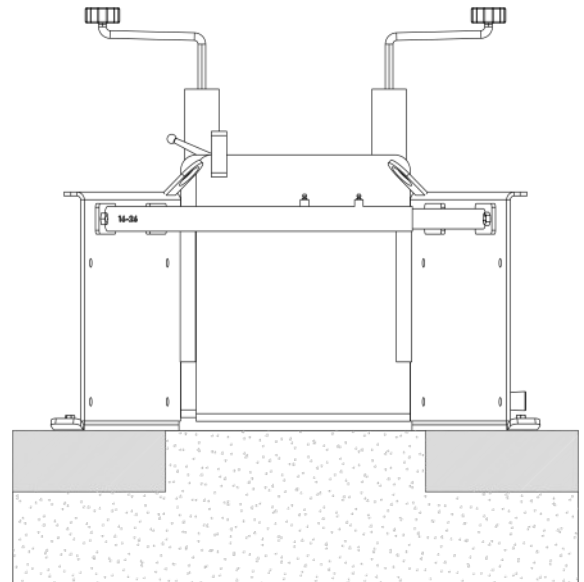

Screeds can be adjusted in height, up to 3" above grade, to use in spreading the top coat layer.

3.6 Detaching From Machine



Pinch / Crush Hazard

To ensure safety when working with the paver and machine, it's crucial to follow these guidelines:

Keep Hands and Feet Clear: Always maintain a safe distance from moving parts. Pinch points can lead to serious injuries, so stay alert and avoid placing your hands or feet near any areas where they could be caught.

Maintain Distance During Attaching and Detaching: When attaching / detaching equipment, ensure no one stands between the paver and the machine. This reduces the risk of accidents, as the area can become hazardous when machinery is in motion.

Use Spotters: If possible, use a spotter to guide operations, ensuring that everyone is aware of the movements and potential hazards.

Communicate Clearly: Make sure everyone involved in the operation understands the plan and signals for safe operation.

- Move paver to a storage location.
- Release all hydraulic pressure (If applicable).
- Disconnect the hydraulic hoses. Do not allow the hoses to lie on the ground (If applicable).
- Board the machine and detach the paver.

4. Transporting

4.1 Highway and Transport Safety

Refer to “2.4 General Safety” on page 8 for additional safety information.

SAFETY INSTRUCTIONS

- Make sure the machine being used is in good operating condition according to the OEM user’s manual.
- When transporting the paver on the highway, make sure the machine has clearly visible “Slow Moving Vehicle” placard.
- Use approved accessory lighting, flags, or other necessary warning devices to protect operators of other vehicles on the highway during daylight and nighttime transport.
- Make sure that the area is clear of children, animals, and other obstacles before moving the paver. This is particularly important with higher noise levels and quiet cabs, as you may not hear people shouting.
- Do not allow anyone to ride on the machine or the paver.
- Always drive at a safe speed relative to conditions, and ensure that the speed is low enough for an emergency stop. Keep speed to a minimum.
- Reduce speed prior to turns to avoid the risk of overturning.
- Always keep the machine in gear to provide engine braking when going downhill. Do not coast.
- Be a safe and courteous driver. Always yield to oncoming traffic in all situations, including narrow bridges, intersections, etc. Plan your route to avoid heavy traffic.

- Watch for overhead obstructions and side clearances while transporting.
- Always operate paver in a position to provide maximum visibility at all times. Make allowances for increased length and weight of the paver when making turns, stopping, etc.

4.2 Pre-transport Checklist

- Before transporting, make sure the maintenance on the machine is current.
- Check the tire pressures on the machine and correct if necessary.
- Make sure the paver is securely attached to the machine. Always inspect the paver for damage or abnormal wear before detaching.
- Prior to transporting on a public road, have an observer confirm all running lights, brake lights, turn signals, and hazard lights are working on the machine.
- Verify the brakes are operating correctly.

5. Storage

Refer to “2.4 General Safety” on page 8 for additional safety information.

SAFETY INSTRUCTIONS

- Do not store the paver where it will be exposed to livestock. Damage and livestock injury could result.

CAUTION



Stay Clear

Do not permit anyone, especially children to play on, or around, the stored paver. Store the paver in an area away from human activity.

5.1 Placing in Storage

To properly prepare and store the paver, follow these steps:

Set the Screed: Adjust both screeds to be resting on level surface. This ensures the paver is in a neutral position for storage.

Wash the paver: Use a pressure washer or water hose to thoroughly clean the paver. This will help remove all loose dirt, mud, and debris, which can prevent corrosion and maintain the equipment’s condition.

Select a Suitable Storage Area: Choose a storage location that is dry, level, and free of debris. Ideally, this should be inside a building to protect the paver from the elements.

Move the paver to Storage: Safely relocate the paver to its designated storage area, ensuring the path is clear of obstacles.

Lower the paver: Once in the storage area, lower the paver to the ground to stabilize it.

Disconnect Hydraulic Couplers: Carefully disconnect the hydraulic couplers and detach the paver from the machine. Ensure that hoses do not lay on the ground to avoid damage or contamination.

By following these steps, you can ensure the paver is stored safely and is ready for future use.

5.2 Removing from Storage

Attach the paver to the machine following the procedure in section “3.3 Initial Setup and Attachment” on page 11.

Before placing paver back into service, replace any work or defective parts and perform the Pre-Operation Checklist. Refer to “3.4 Pre-Operation Checklist” on page 12.

6. Maintenance

Good maintenance is the responsibility of both the owner and operator. Poor maintenance can shorten the life of the paver and invite various problems.

Roadrunner Eqpt. LLC will not accept responsibility for the use of unapproved parts and/or accessories, nor for any damages resulting from their use.

If the paver has been altered in any way from its original design, the manufacturer does not accept any liability for injury or warranty claims.

6.1 Maintenance Safety

WARNING



Roll Away Hazard

Before working on this paver, ensure the following safety measures are in place: the engine is stopped, the transmission is in park, the key is removed, and the parking brake is set.



Personal Protection Equipment (PPE)

Wear properly fitting and belted clothing to avoid getting caught in moving parts. Additionally, use personal protective equipment (PPE), which may include safety glasses, safety shoes, gloves, and other items appropriate for the worksite and working conditions.



No Unauthorized Modifications

Do not modify the paver or its safety devices. Avoid welding on the paver. Unauthorized modifications may impair the paver's function, create safety hazards, and will void the warranty. If the paver has been altered in any way from its original design, the manufacturer does not accept any liability for injury or warranty claims.



Crush Hazard

Always set the paver on blocks or on the ground when performing maintenance.



OEM Replacement Parts

If replacement parts are necessary, genuine factory replacement parts must be used to restore the paver to its original specifications. Unapproved parts could create a safety hazard. The manufacturer will not accept responsibility for damages as a result of the use of unapproved parts.

6.2 Practice Safe Service Procedures

CAUTION



Understand service procedures before doing any work. Keep the work area clean and dry.



Keep all parts in good working condition and properly installed.

Replace worn or broken parts immediately.



A first aid kit should be readily accessible while performing maintenance on the paver.



Do not leave tools lying around the work area.

Follow good shop practices. Keep service area clean and dry. Be sure electrical outlets and tools are properly grounded. Use adequate light. After servicing, be sure all tools, parts and service equipment are removed.



Use the correct tools, jacks, hoists, or other tools that have the capacity for the job.

6.3 Bolt Torque Requirements

WARNING



Equipment Failure

The correct torque value for bolts and cap screws is indicated by their head markings. Replacing higher-grade bolts (such as Grade 5) with lower-grade ones can cause equipment failure and may lead to injury or even death. Always ensure that replacement bolts match the grade markings of the original bolts.

It is crucial to apply and maintain the proper torque on all bolts. Use a torque wrench to ensure the correct amount of torque is applied to the fastener.

Always start bolts or nuts by hand to prevent cross-threading.

The torque values indicated in the chart are for non-greased or non-oiled threads unless otherwise specified. Therefore, do not grease or oil bolts or cap screws unless directed by this manual. When using locking elements, increase the torque values by 5%.

The chart provides the correct torque values for various bolts and cap screws. Tighten all bolts to the specified torque unless noted otherwise. Periodically check the tightness of bolts, using the bolt torque chart as a reference. Always replace hardware with bolts of the same grade.

Bolt Diameter	Imperial Bolt Torque Specifications					
	Grade 5		Grade 8		ASTM A574	
	3 Radial Lines		6 Radial Lines		Socket Head Cap Screw	
	ft.lbs.	N·m	ft.lbs.	N·m	ft.lbs.	N·m
1/4"	9	12	12	17	14	18
5/16"	19	25	27	36	29	38
3/8"	33	45	45	63	51	69
7/16"	53	72	75	100	81	109
1/2"	80	110	115	155	124	168
9/16"	115	155	165	220		
5/8"	158	215	220	305	238	322
3/4"	290	390	398	540	423	573
7/8"	420	570	650	880	682	924
1"	630	850	970	1320	1022	1385

6.4 Welding Repairs



Before performing any type of welding repair to the paver, contact Roadrunner Equipment for approval. Repair welding should be executed with caution and may require procedures that exceed the capabilities of a typical welder.

WARNING



Personal Injury Hazard

Repairs or modifications to the paver could result in serious injury or death to the operator or bystander should these repairs fail.

NOTICE

Anyone performing a welding repair should be certified in accordance to the American Welding Society (AWS) standards.

6.5 Service Record

The service period recommended is based on normal operating conditions. Severe or unusual conditions may require more frequent service.

Copy this page to continue record.

Hours / Serviced By													
Maintenance													
Every 8 Hours of Use													
Make sure all retainer clips and pins are in place.													
Clean all of the paver's surfaces thoroughly.													
Grease manual width adjustment thread and telescoping tubes.													
Every 40 Hours of Use													
Inspect screeds for wear.													
Inspect skid bars for wear.													
Annually													
Make sure all fasteners are tightened to proper torque. Refer to "8.2 Bolt Torque Requirements" on page ***													
Wash the paver.													
Inspect the frame for cracking or damage.													

7. Parts Section

7.1 Ordering Parts

Roadrunner Eqpt LLC produces high-quality products that require minimal maintenance or repairs. However, if a part happens to break or get damaged, our expert team is ready to ensure you receive the necessary replacement parts to get your paver back in operation quickly.

7.2 Contact Information

For questions, or to order products or parts, contact:

Roadrunner Equipment LLC
155 Jalyn Drive
New Holland, PA 17557

Phone: 717.405.7785
contact@roadrunnerblade.com
www.roadrunnerblade.com

7.3 Bill of Materials

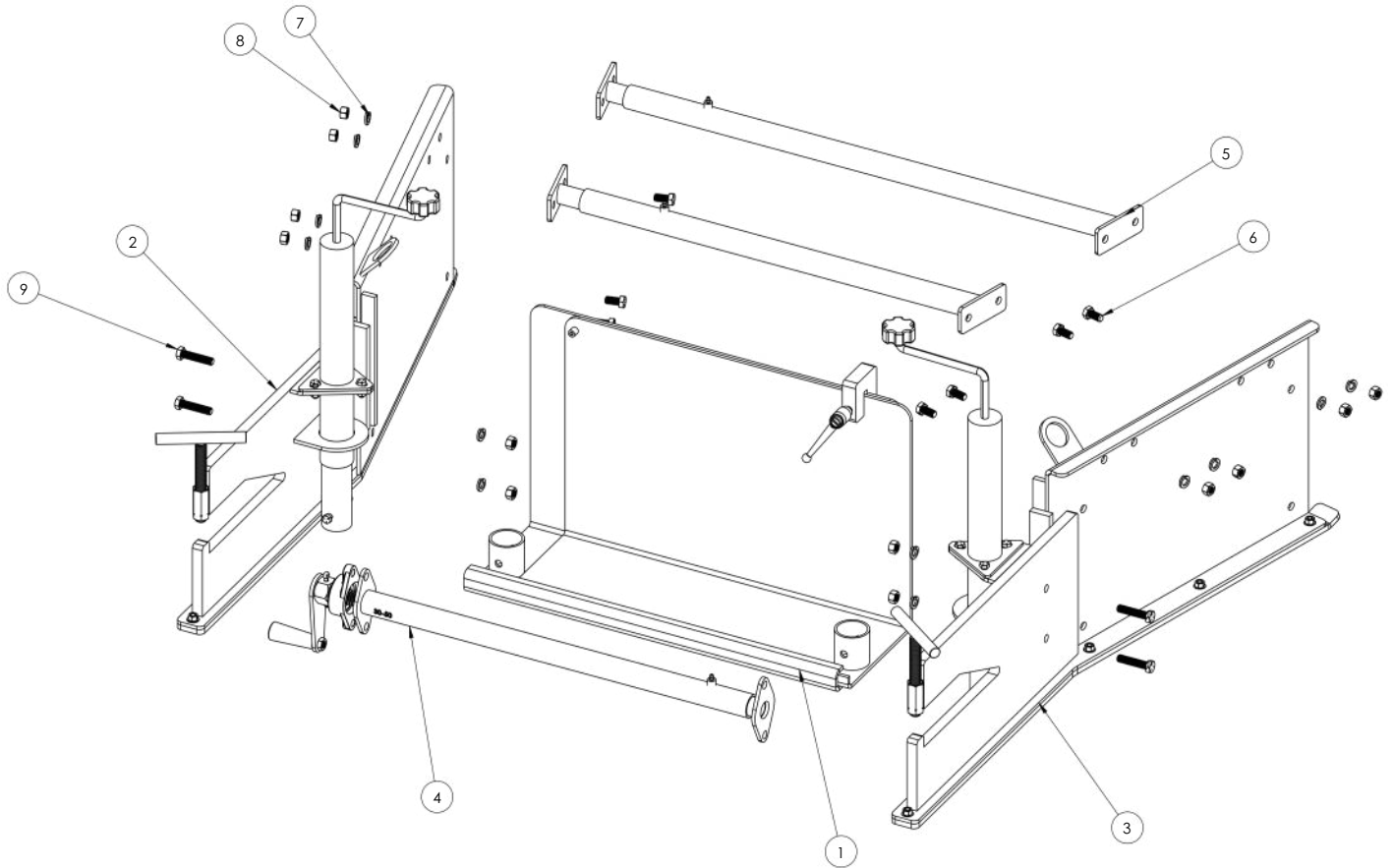

Item	Description
1	Screed Assembly *
2	Multi-Task Paver, Left Side
3	Multi-Task Paver, Right Side
4	MT Width Adjustment Assembly *
5	TeleTube Assembly *
6	Bolt, 1/2"-13 Thread, 1" Long
7	Split Lock Washer, 1/2"
8	Nut, 1/2"-13 Thread
9	Bolt, 1/2"-13 Thread, 2-1/4" Long

*Size dependent on model#.

7.4 Screeds

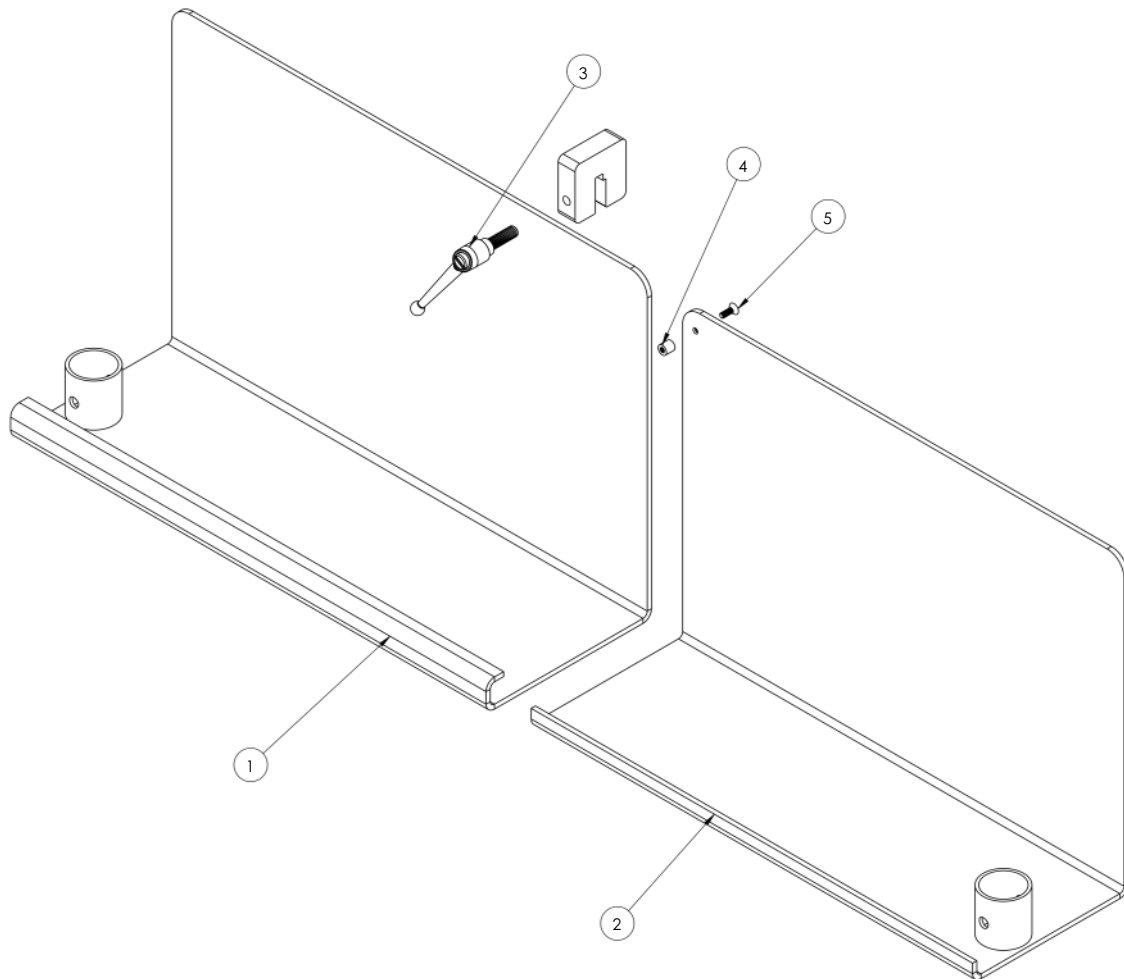

Item	Description
1	Outside Screed *
2	Inside Screed *
3	Handle, Screed Clamp
4	Screed Stand-off Stop
5	1/4-20 Flat Head Screw, 3/4" Long

*Size dependent on model#.

7.5 Side Panel

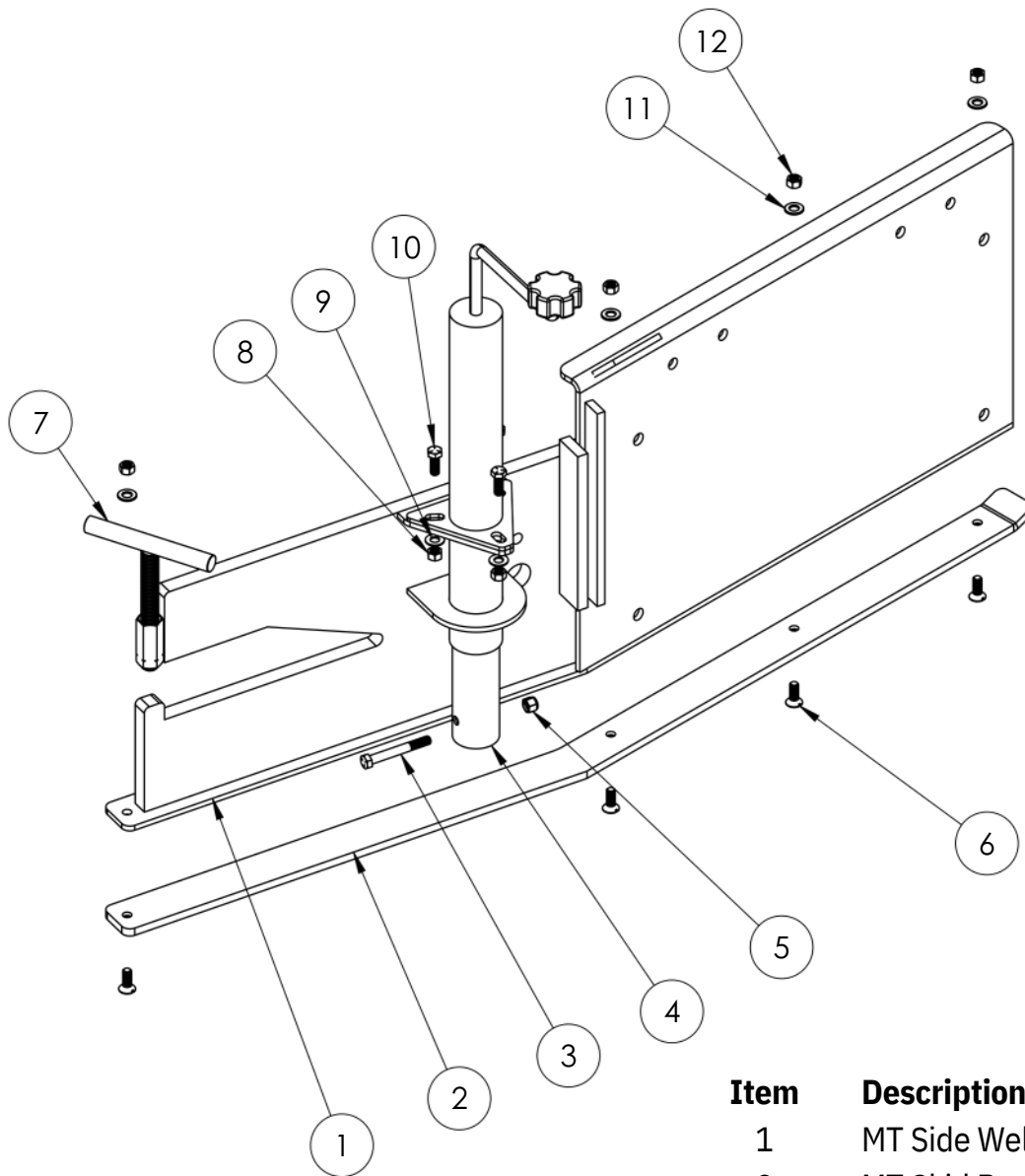

Item	Description
1	MT Side Weldment
2	MT Skid Bar
3	Bolt, 3/8"-16, 3" Long
4	Jack
5	Locknut, 3/8"-16
6	Screw, Flat, 3/8"-16, 1" Long
7	Bucket Mount Handle
8	Nut, 3/8"-16
9	Washer, 3/8"
10	Bolt, 3/8"-16", 1" Long
11	Washer, 3/8"
12	Nut, 3/8"-16

*Left side shown.

7.6 Width Adjustment

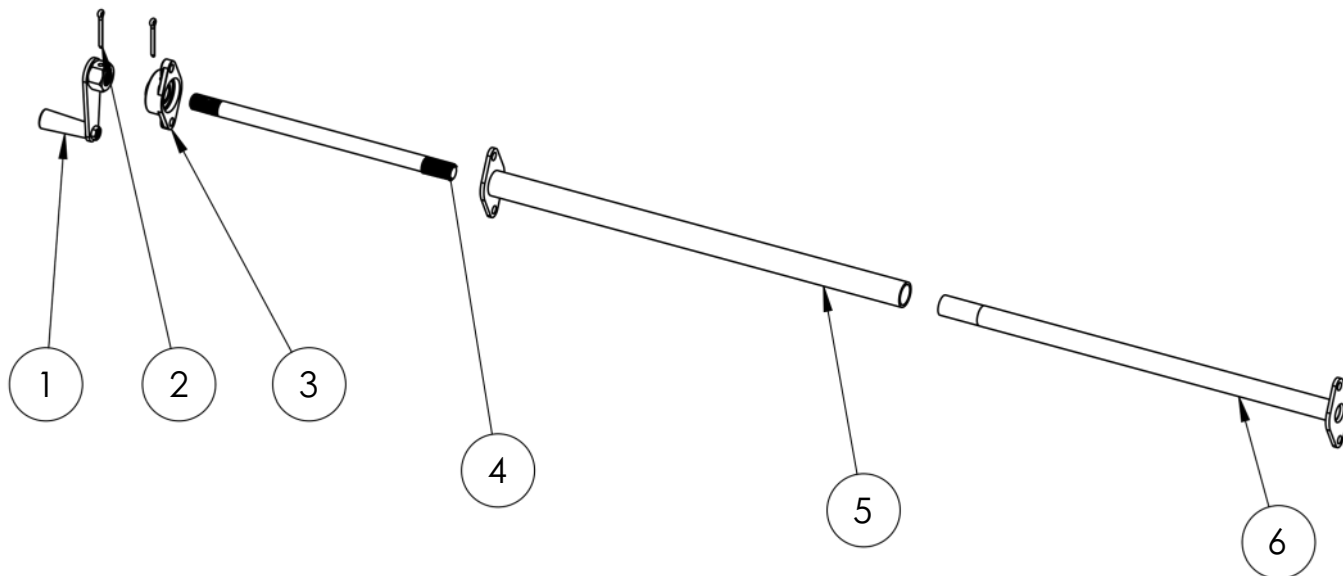

Item	Description
1	MT Screw Handle
2	Cotter Pin, 1/4" x 2"
3	Bearing with Two-Bolt Flange
4	ACME Screw *
5	Outside Screw Tube Weldment *
6	Inside Screw Tube Weldment *

*Length dependent on model#.

7.7 Teletubes

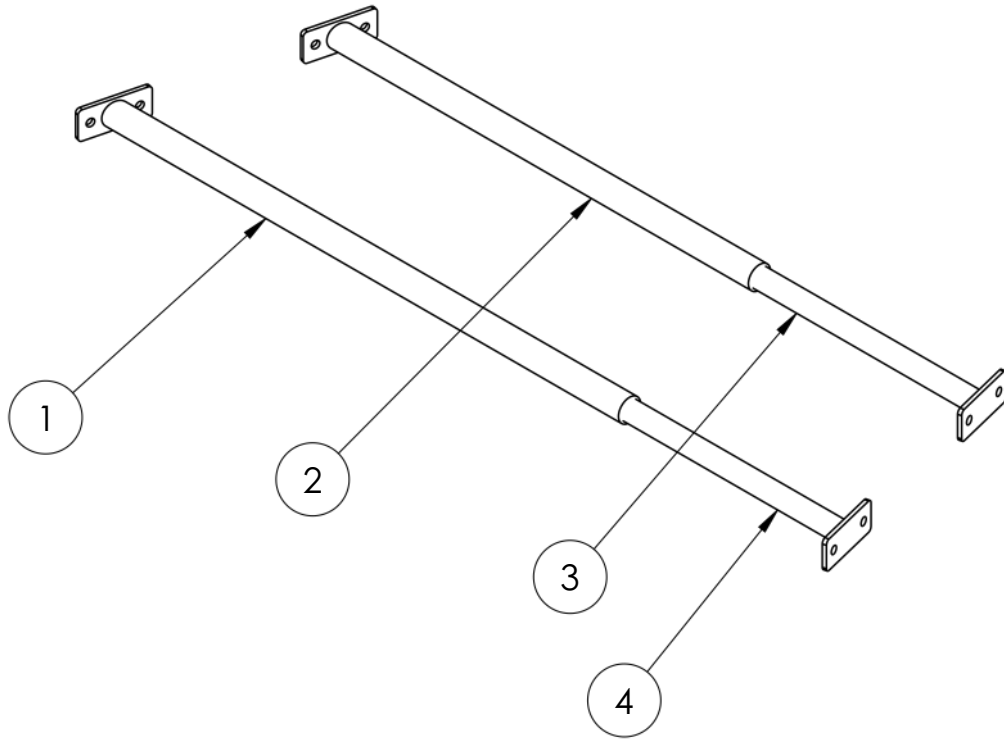

Item	Description
1	Outside, Long, TeleTube
2	Outside, Short, TeleTube
3	Inside, Short, TeleTube
4	Inside, Long, Teletube

*Width dependent on model#.

7.8 Decals



Part#: Decal_MT_SP
Description: Decal, MT-Series Side Panel

8. Warranty

Limited Warranty

Roadrunner Equipment LLC products are warranted to be free from defects in workmanship or materials for a period of 36 months from the initial sale, lease, or rental date.

Warranty Exclusions

This warranty does not cover normal wear items, including but not limited to bearings, hoses, ground-engaging parts such as teeth, blades, cutting edges, and skid shoes.

This warranty does not cover maintenance, service, or adjustments. It also does not cover damage due to misuse, negligence, accidents, or improper maintenance. Damage resulting from improper application, installation, contamination, adjustment, or setup is not covered. Additionally, damage caused by improper modifications of the product is excluded. The warranty is void if any components have been disassembled, such as pumps, gearboxes, or motors.

This warranty does not cover replacement parts not supplied by Roadrunner Equipment LLC.

Warranty Statement

Our obligation under this Limited Warranty is solely limited to repairing or replacing, free of charge, any part (see non-covered items) that, in our judgment, shows evidence of a defect in workmanship or materials during the 36-month warranty period. All defective parts must be returned directly to Roadrunner Equipment LLC with freight or delivery charges prepaid. This Limited Warranty does not render Roadrunner Equipment LLC liable for any injury or damage to persons, businesses, or property of any kind, nor for expenses or losses incurred for labor, supplies, substitute machinery rental, or any other reason. Repair or replacement parts are subject to the supply conditions at the time of repair or replacement, which may affect our ability to obtain materials and/or replacement parts. Roadrunner Equipment LLC reserves the right to make design improvements or changes in specifications at any time without incurring any obligations to owners of previously purchased units. Only Roadrunner Equipment LLC is authorized to alter, modify, or enlarge this warranty or its exclusions, limitations, and reservations.



ROADRUNNER
EQUIPMENT LLC.

Roadrunner Equipment LLC
155 Jalyn Drive
New Holland, PA 17557

717.405.7785
www.RoadRunnerBlade.com
contact@roadrunnerblade.com